

## Dimensions

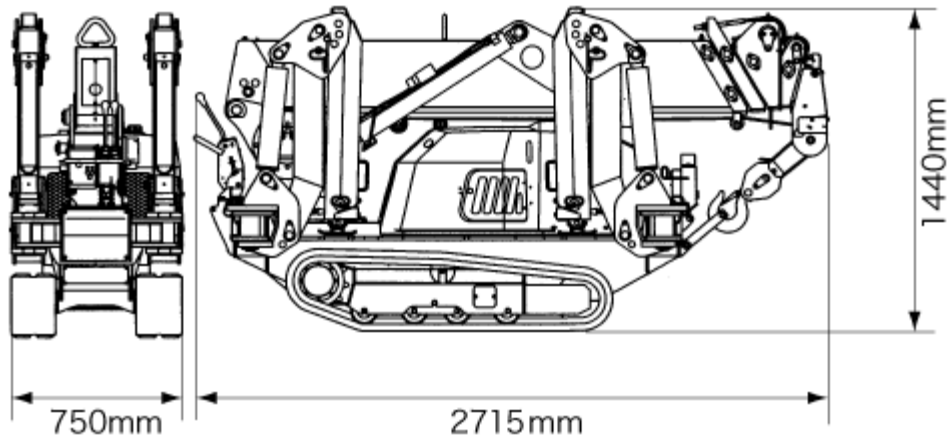

## Technical specifications

Model		MC285CRM(E)	
Crane capacity	t×m	2.82t×1.4m	
Max. working radius	m×t	8.205m×0.150t	
Max..lifting height (on the ground)	m	8.7m	
Max..lifting height (underground)	m	-10.1m (4 falls)	
Winch system	Hook speed	m/min	8.0m/min (3 layers , 4 falls)
	Hoist wire rope	Ø×m	IWRC 6 X Fi (29) 0/0, Ø7×48.0m
Telescoping system	Type	Fully automatic 5-section pentagonal telescopic boom	
	Boom length	m	2.535~8.575m
	Boom telescoping stroke / time	m/sec	6.04m/22.0sec
Boom hoist system	Hoist angle / time	deg/sec	0~80deg/14.0sec
Swing system	swing angle / time	deg/rpm	360deg/0.9rpm
Outrigger	Type	1st stage with flexible stay damper, 2nd stage manual pullout hydraulic cylinder direct acting type	
	Max.extended width	mm	(Lateral)4,580× (Front)4,530× (Rear)3,810
Travel system	Type	Hydraulic motor driven , step-less speed changer	
	Travel speed	km/h	0~2.20
	Tandem track roller	Available	
	Grade ability	deg	20.0
	Crawler ground lengt × width	mm	975×200
	Ground pressure	kpa [kgf/cm <sup>2</sup> ]	47.8 [0.49]
	Minimum ground	mm	133

	clearance		
Engine	Model		YANMAR 2TNE68-MB
	Displacement	L [cc]	0.523 [523]
	Rated output	kw/min <sup>-1</sup> [ps/rpm]	6.57/2,600 [9.0/2,600]
	Starting method		Electric starting
	Fuel / Fuel tank capacity	L	Diesel/12.0
Motor (MC285CRME)	Motor type		Totally enclosed fan-cooled motor 5.5kw,4P,200V, or 380V
	Starting system		Inverter system (30Hz-60Hz)
Remote control system	Type		Cable remote controller
	Micro-speed mode		Available
	Outrigger operation		Available
Overall length × width × height		mm	2,715×750×1,440 (3,285×750×1,525 with motor)
Machine weight		kg	1,770kg (1,950kg with electric motor)
Safety device			Overwind protection, Load indicator, Hydraulic safety valve, Load meter, Wire rope latch, Warning buzzer, Level, Machine body inclination alarm, EMO switch, Moment limiter, Rotary lamp
Option			white rubber track, single fall hook, 2 falls hook

#### Total Rated Load Chart (4 falls)

Total Rated Load Chart with outrigger extended to maximum							
4.075m boom		5.575m boom		7.075m boom		8.575m boom	
Working Radius (m)	Total Rated Load (kg)	Working Radius (m)	Total Rated Load (kg)	Working Radius (m)	Total Rated Load (kg)	Working Radius (m)	Total Rated Load (kg)
1.4 or less	2820	3.0 or less	1220	3.6 or less	820	4.0 or less	550
1.50	2520	3.50	970	4.00	740	4.50	400
2.00	1920	4.00	780	4.50	580	5.00	340
2.50	1570	4.50	630	5.00	480	5.50	300
3.00	1220	5.00	530	5.50	430	6.00	270
3.50	970	5.205	530	6.00	380	6.50	230
3.705	920			6.50	350	7.00	200
				6.705	330	7.50	180
						8.00	150
						8.205	150

\* The Total Rated Load Chart is based on actual working radius with the bending of boom attributable to load reflected and is shown with the mass of hook (20kg) included.

# Working Range Chart

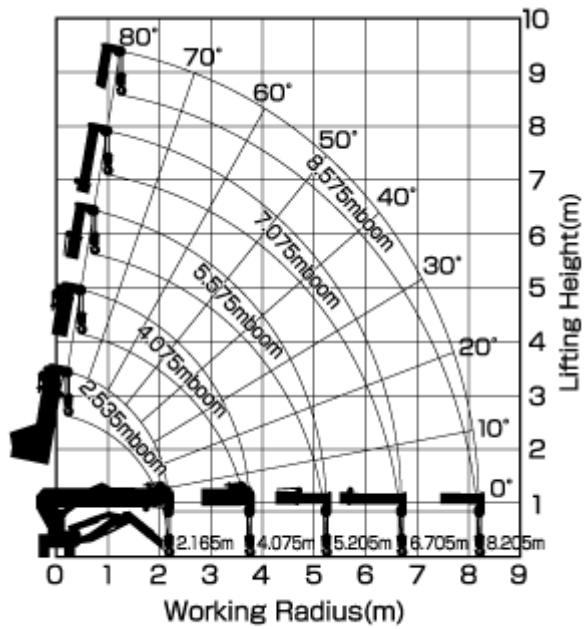

\*The working range chart applies to cases without load and do not include boom deflections.

